

Wind Energy Institute of Canada

Leading the development of wind energy across Canada through research, testing, innovation, and collaboration.

The Wind Energy Institute of Canada (WEICan), located in North Cape, Prince Edward Island, has been leading the development of wind energy across Canada through technical testing and consultation; research, development and demonstration; and outreach since its formation in 1981. As a national research facility and independent wind farm and battery energy storage system operator, with strong industry ties, the Institute is well-positioned to lead research in the advancement of wind energy.

WEICan owns and operates a Wind R&D Park that features five 2 MW wind turbines and an energy storage system with a 1 MW/2 MWh capacity. The Institute views this infrastructure as a laboratory that is available for research and is open to collaboration with interested parties.

WIND R&D PARK LABORATORY

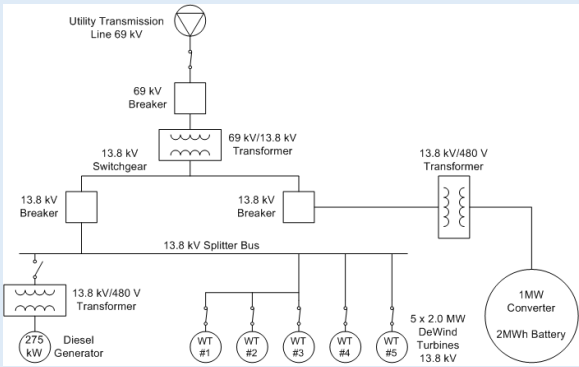

Fig 1. Single line diagram of the wind park layout



Fig 2. Battery Energy Storage System at the Wind R&D Park (the substation and a turbine are in the background)

5 DeWind D9.2 2 MW wind turbines

- 92 m blade diameter turbines; 4 m/s cut in; full production at 10.5 m/s.
- Equipped with synchronous generators to support the grid during faults.

275 kW diesel generator.

- Provides power during extended outages for turbine ancillary functions, such as yawing to protect during high wind events.

Wind R&D Park substation

- Substation maintained by Maritime Electric for 69 kV grid tie in.

Test bed for energy storage system

- Composed of a power conversion system and battery modules.
- Currently houses a 1 MW/2 MWh battery energy storage system.

Fully equipped meteorological masts

- 80 m IEC meteorological mast located at the Wind R&D Park site equipped with multiple direction and wind speed sensors including an ultrasonic sensor at multiple heights..
- Newly installed ice detector allows further research into ice propagation.
- Newly installed pyranometer allows measurement of solar irradiance.
- 60 m meteorological mast located at the WEICan site with data recorded since 1982.

Wind turbine condition monitoring systems

- A blade condition monitoring system, manufactured by Woelfel, is installed on the blades of one turbine at the WEICan Wind R&D Park. It can detect risk of incipient damage in the blades.
- The CMaS gearbox condition monitoring is installed on all five turbines and monitors various parameters to determine the gearbox performance and anticipates possible upcoming failures.
- WEICan is currently evaluating whether investing in additional CMSs would be prudent

Supervisory control and data acquisition (SCADA) system

- The SCADA system used at the WEICan Wind R&D Park provides real time interface and controls between the various systems including wind turbines, the local utility, battery storage system, and substation equipment.

PI, the Real-time Data and Event Infrastructure, created by OSIsoft

- The PI system will collect, analyze, visualize, and share large amounts of high fidelity time-series data from multiple sources from all of the above components as well as the WEICan small wind test site into one common database.



Contact:

Marianne Rodgers, Ph.D.
Scientific Director
(902) 882-2746 Ext. 207
marianne.rodgers@weican.ca